

DATI MOTORE E CURVE CARATTERISTICHE / PERFORMANCES AND MOTOR RATINGS

Tensione / Voltage	V ±10%	380	0	0
Potenza resa / Output Power	kW	2 (2,4)	0	0
Corrente nom. / Current	A	4,8 (5,7)	0	0
Frequenza / Frequency	Hz	200	0	0
rpm	rpm	12000	0	0
Coppia nom. / Torque	Nm	1,59 (1,9)	0,00	0,00
Cuscinetto Ant. / Front Bearing		radiale / radial		
Cuscinetto Post. / Post. Bearing		radiale / radial		
Rendimento / Efficiency	η	0,9		
Fattore di potenza / Power factor	cos φ	0,7		
Numero di poli / Poles		2		
Tipo di servizio / Service type		S1 (S6 40%)		
Classe di isolam. / Insulation class		F		
Raffreddamento / Cooling		Aria forzata / Forced air		
Peso / Weight	Kg	~ 7		
Grado IP / Type of Protection	IP	50		

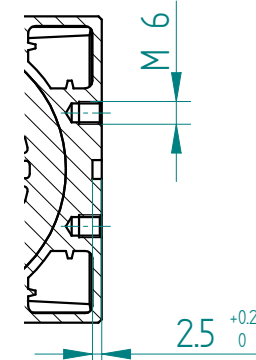

ATTENZIONE!!!
NON FAR GIRARE L'ELETTROMANDRINO
SENZA L'UTENSILE INSERITO
WARNING!!!
DO NOT RUN THE ELECTROSPINDLE
WITHOUT TOOL



SEZIONE A-A

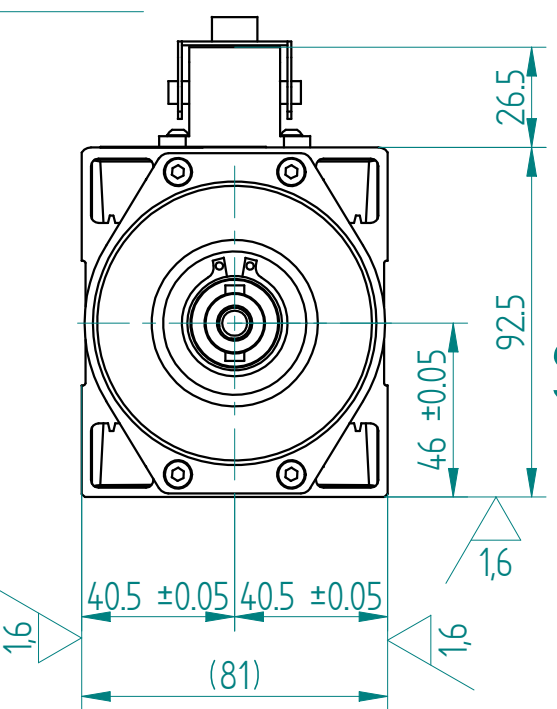
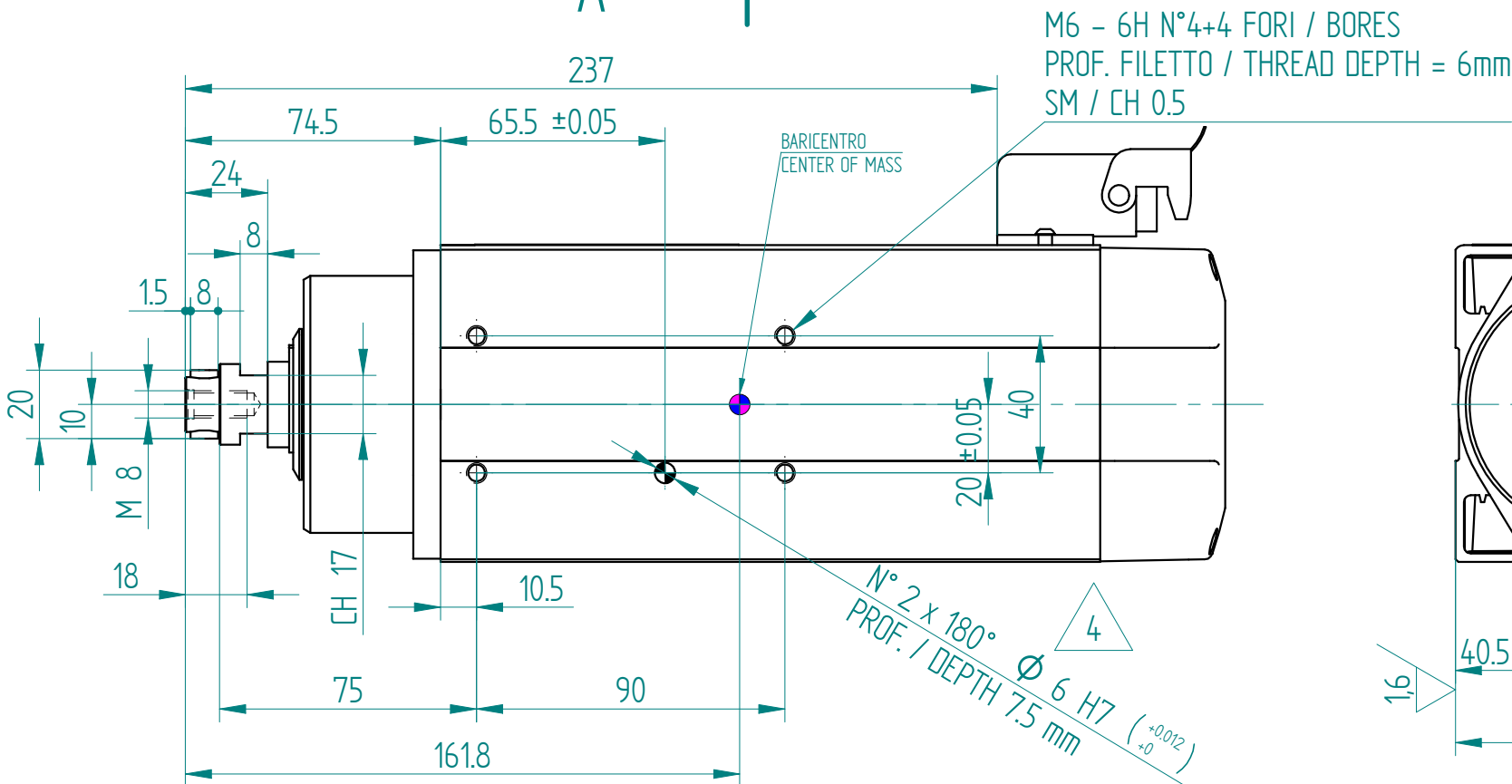

CONNESSIONI ELETTRICHE / ELECTRIC CONNECTIONS

Nr. Pin	Descrizione / Description
1	U Fase / Motor phase
2	V Fase / Motor phase
3	W Fase / Motor phase
4	** Bimetallo / Bi-metallic
5	** Bimetallo / Bi-metallic
	Terra elettromandrino / Earth connection

** Vedi "Manuale istruzioni ed avvertenze per l'uso" per le caratteristiche tecniche
 ** See "User's guide" for technical informations

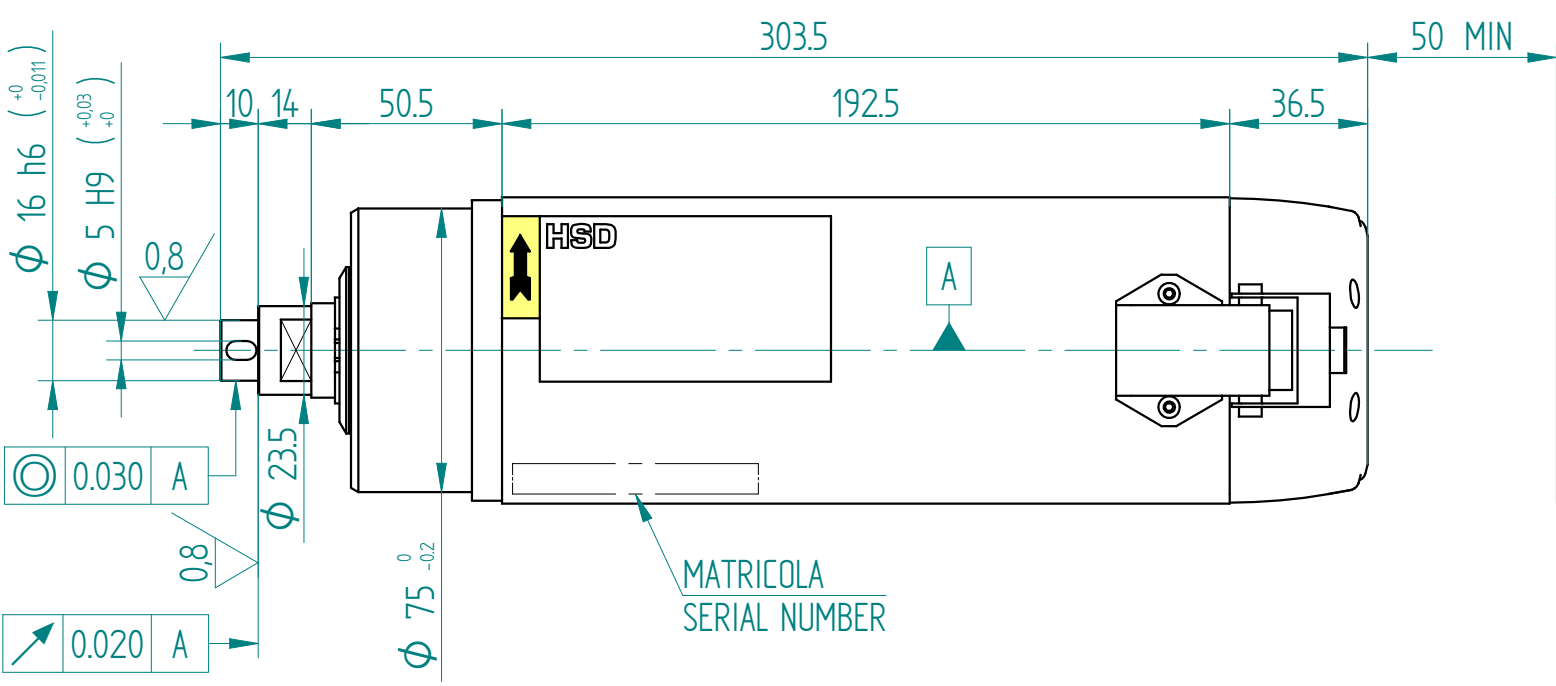

2	Agg. quota 46±0.05	11/5/2011	M.B.	
3	Aggiunti n°2 fori φ6H7	30/11/2011	L.L.	
4	Aggiunti n° 2 fori φ6H7	30/11/2011	L.L.	
REV.	DESCRIZIONE REVISIONE / REVISION DESCRIPTION	DATA / DATE	FIRMA SIGN	
	DISEGNATO / DRAW BY	CONTROLLATO / CHECKED BY	APPROVATO / APPROVED	SCALA : SCALE: 1 : 2
DATA DATE	15/9/2010			PESO : WEIGHT : 6,910 kg
FIRMA SIGN	Bugari M.			GREZZO DI : RAW : SOSTITUISCE : REPLACE :
MATERIALE : MATERIAL :				- GETTI / MELT CASTING :
TRATTAMENTO TERMICO : HEAT TREATMENT :				
RIVESTIMENTO SUPERFICIALE : SURFACE TREATMENT :				
DENOMINAZIONE : DESCRIPTION :	AT1073-120-2,4KW-S6-LING-380V-DX-12/12000-C			
				CICLO DI VERNICIATURA : PAINTING CYCLE :
				REVISIONE REVISION 4
				CODICE ARTICOLO DRAW N° 6164H0011

RIPRODUZIONE E/O DIFFUSIONE VIETATA / REPRODUCTION AND OR DISCLOSURE OF THE DRAWING IS FORBIDDEN