

FLANGIA DISTRIBUZIONE ACQUA
Water Flange
 SUPPORTO ELETTROMANDRINO
Electrospindle housing
 ELETTROMANDRINO
Electrospindle

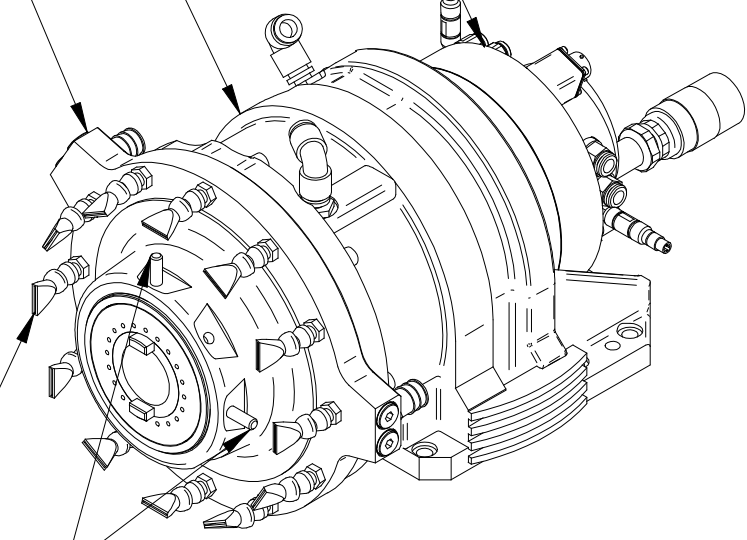

SPINE DI POSIZIONAMENTO PER ATTREZZATURE
 (ESTRAIBILI E RIPOSIZIONABILI)
*Pins for equipment positioning
(removable and remountable)*

UGELLI ORIENTABILI LIQUIDO REFRIGERANTE
 UTENSILE ESTERNO
Adjustable nozzles for outside tool cooling

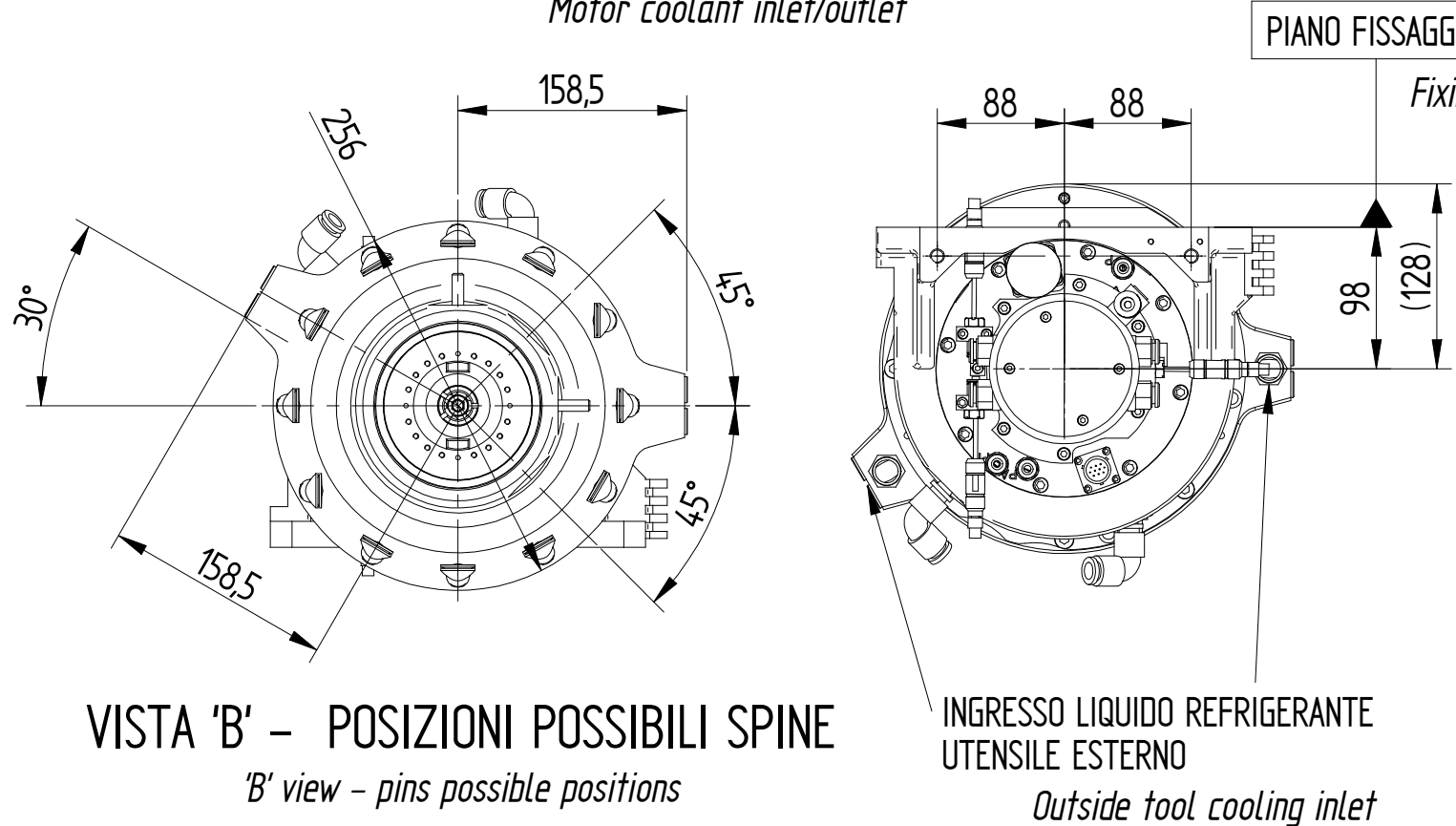

RIPRODUZIONE E/O DIFFUSIONE VIETATA REPRODUCTION AND OR DISCLOSURE OF THE DRAWING IS FORBIDDEN				1		Agg. seconda lingua	14/11/2011	M.S.		
				REV.	DESCRIZIONE REVISIONE / REVISION DESCRIPTION					
DATA DATE	28/01/2011	CONTROLLATO / CHECKED BY	28/01/2011	APPROVATO / APPROVED	SCALA : SCALE :	1 : 5		QUOTE SENZA INDICAZIONE DI TOLLERANZA POSITIONS WITHOUT TOLERANCE INFORMATION - LAVORAZIONI MECCANICHE : - MECHANICAL WORKINGS :		
FIRMA SIGN	Memoli S.	Pietropaolo A.			PESO : WEIGHT :			- SALDOCARPENTERIE : - WELDMENT :		
MATERIALE : MATERIAL :					GREZZO DI : RAW :			- GETTI : - MELT CASTING :		
TRATTAMENTO TERMICO : HEAT TREATMENT :					SOSTITUISCE : REPLACE :			0 1		
RIVESTIMENTO SUPERFICIALE : SURFACE TREATMENT :					CICLO DI VERNICIATURA : PAINTING CYCLE :			CODICE ARTICOLO DRAW N° 5530H0615		
DENOMINAZIONE : DESCRIPTION :					DIM. ES796 WATER FLANGE					